

OPERATOR'S MANUAL

CM1265B1XXXXXXX

INCLUDING: OPERATION, INSTALLATION AND MAINTENANCE.

RELEASED: 5-14-10
(REV. 01)

INCLUDE MANUALS: AF1265BXXXXXX-XX-X Pump (97999-1527), 66554-X CART (PN 97999-574) & S-632 General Information (pn 97999-624).

12" AIR MOTOR
65:1 RATIO
6" STROKE

CART MOUNT PUMP PACKAGE CARBON STEEL, TWO BALL PUMP



**READ THIS MANUAL CAREFULLY BEFORE INSTALLING,
OPERATING OR SERVICING THIS EQUIPMENT.**

It is the responsibility of the employer to place this information in the hands of the operator. Keep for future reference.

SERVICE KITS

- Use only genuine ARO® replacement parts to assure compatible pressure rating and longest service life.
- **637489** for repair of air motor section.
- **637098-XX3** for repair lower pump end.

MODEL DESCRIPTION CHART

CM 12 65 B 1 XXXXX X	
Package CM - Cart Mount	
Air Motor Size 12 - 12"	
Pump Ratio 65 - 65:1	
Check Type / Wetted Materials B - 2 Ball, Carbon Steel Nickel-Plated	
Container Suitability 1 - Stub	
Lower Pump End Options Refer to pump model operator's manual	
Package Option 0 - None 1 - Integrated Ball Valve Regulator on Pump	

⚠ WARNING HIGH PRESSURE DEVICE. Improper usage of equipment could result in serious injury. The possibility of injection into the flesh is a potential hazard. Never allow any part of the human body to come in front of or in direct contact with the material outlet. An injection can be serious! If injection should occur, contact a qualified physician for immediate treatment of such injuries.

⚠ WARNING Do not exceed maximum working pressure of 5850 p.s.i. (6.2 bar) air inlet pressure.

CM1265B1XXXXXXX

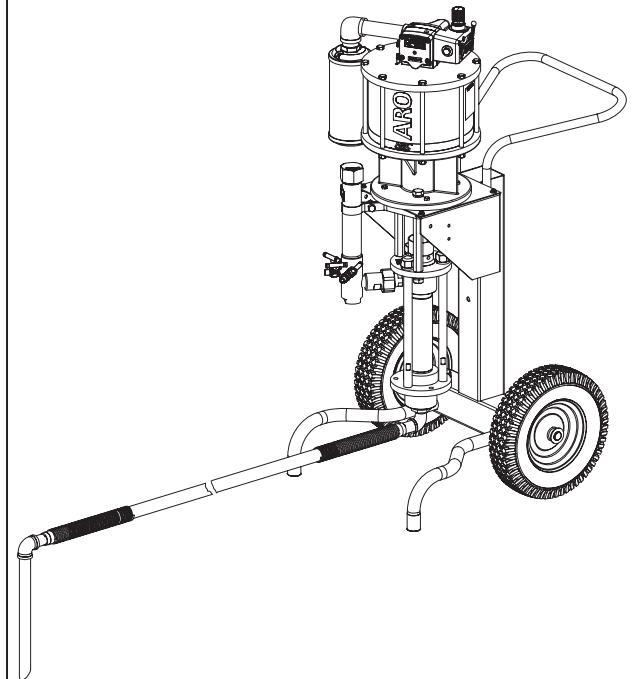

Figure 1

GENERAL DESCRIPTION

By delivering a smooth, continuous bead of the proper size, an ARO® system helps the operator maintain both production rate and produce high quality standards. Maintained quality standards assures that the material benefits are realized. To further maximize operator production time, the ARO system has a built-in lift / ram feature for quick and easy drum changeover and easy lifting of the pump assembly from the container.

ARO systems are totally enclosed, sealing the material in the system from air and moisture, preventing premature cure-out of the material. This allows for either continuous or intermittent use of the system and allows the need for daily system clean-up.

The Pump and Cart Assembly is designed to provide portability to a pump that is primarily used for airless spraying applications.

Materials of light to medium viscosity are suited for the unit.

INSTALLATION

The unit comes completely assembled.

Spray gun and hoses are not included with this unit.

These items must be capable of withstanding 5850 p.s.i. (403 bar) working pressure.

Connect hose (furnished by customer) to 66593 ball valve. This unit can accommodate 3 guns and hoses.

OPERATING INSTRUCTIONS

See AF1265XXXXX pump manual installation for flushing instructions.

Be sure material hoses and other components are able to withstand fluid pressures developed by this pump.

After the pump has been flushed with a compatible solvent and is ready to operate.

1. Place 66728 suction hose assembly into material.
2. Allow pump to cycle slowly and prime with material. This will bleed trapped air from the system.

MAINTENANCE

Periodically check the screen (93945-70 70 mesh) located in the 651418-70-B material filter and pulsation dampener assembly.

TROUBLE SHOOTING

No material (stalled pump).

- Obstructed spray tip. Remove spray tip and clean.
- Obstructed hose assembly. Remove control handle and operate until line is clear.
- Obstructed control handle assembly. Disassemble control handle and clean.

No material (pump continually cycles).

- Empty material supply. Disconnect air. Replace material supply. Reconnect air. Prime pump.

PARTS LIST / CM1265B1XXXXXXX

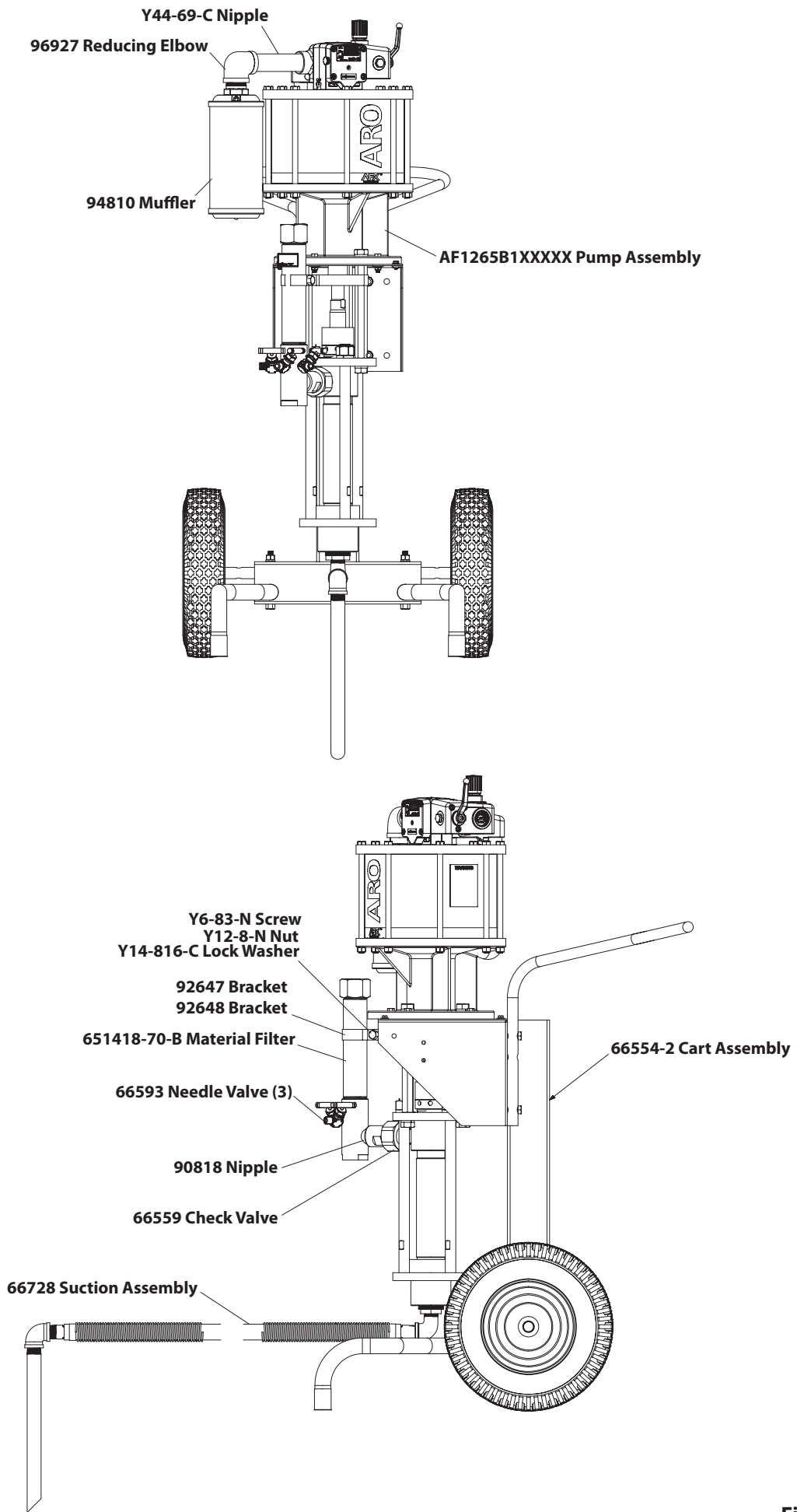

Figure 2

DIMENSIONS

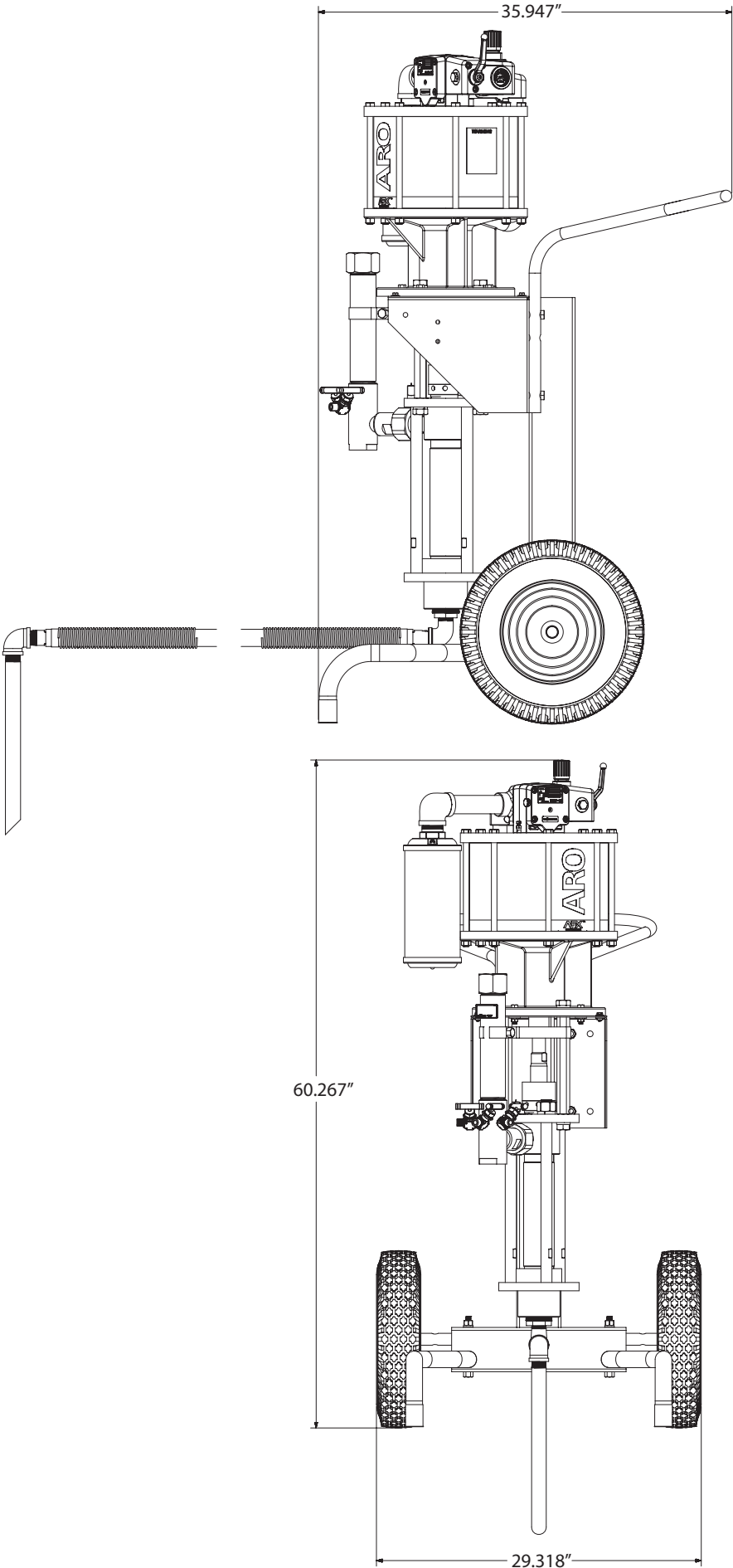

Figure 3